

**FOR PIPE
REPAIRS ONLY**

**CONCRETE COLLAR
SECTIONS**

NOTE:

1. REPAIRS TO BE APPROVED FOR USE BY TOWN ONLY
2. THIS DETAIL COVERS ALL PIPE TYPES EXCEPT FOR METAL PIPE OF DISSIMILAR MATERIALS AND FLEXIBLE PIPE WITH THE MINIMUM COVER.
3. BACKFILL (6" MAX. SIZE), BASE AND SURFACE MATERIAL TO BE PLACED AND COMPACTED PER APPROPRIATE SPECIFICATIONS OR MINIMUM OF 95% PER AASHTO T-180.
4. CONCRETE SHALL BE FORMED AND Poured IN A DRY TRENCH.
5. BITUMINOUS COATING REQUIRED FOR CMP (ANY SUITABLE BITUMINOUS MATERIAL MAY BE FIELD APPLIED) BITUMINOUS COATING TO EXTEND 12" BEYOND CONCRETE COLLAR.
6. ALTERNATE CONNECTION AND/OR COLLAR DETAILS MUST BE APPROVED BY THE TOWN OF JUPITER PRIOR TO INSTALLATION.
7. CONCRETE COLLAR COST SHALL BE PER CUBIC YARD OF CLASS I CONCRETE AS CALCULATED BY USING THE THEORETICAL NEAT LINES AS NOTED ON THIS DETAIL AND AN AGREED UPON COLLAR LENGTH (MIN 2 FT.).
8. PER CUBIC YARD COST SHALL INCLUDE SPECIFIED STEEL AND BACKFILL COMPACTION.
9. INSTALLATION OF ALL PIPE AND STRUCTURES MUST MEET THE BEDDING, INSTALLATION AND BACKFILL REQUIREMENTS FOR NEW STRUCTURES AND PIPE ON DETAIL SW-5.

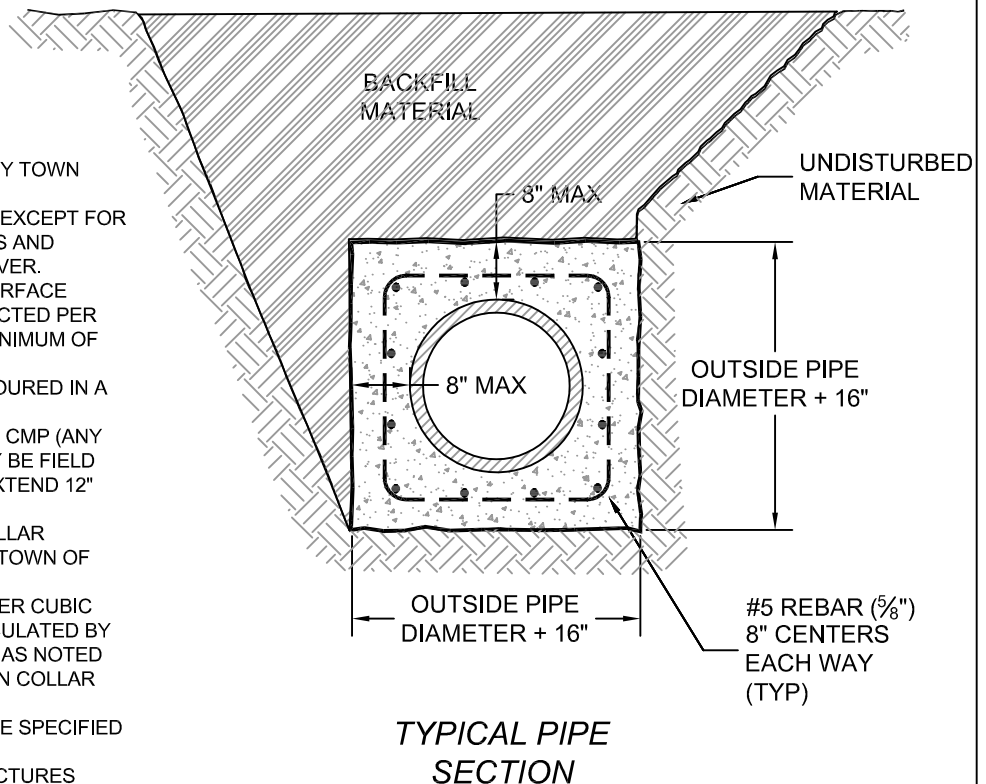

**TYPICAL PIPE
SECTION**

NOT TO SCALE

CONCRETE COLLARS FOR STORMWATER PIPE REPAIRS

**JUPITER UTILITIES
CONSTRUCTION STANDARDS AND DETAILS**

DATE APPROVED:
01/2018
DRAWING No.
SW-19