

PIPE SECTIONS

NOTE:

1. SECURING DEVICES MAY BE ELIMINATED BY DOUBLE WRAPPING PIPE WITH FILTER FABRIC.
2. FOR ALL PIPE TYPES - CONCRETE PIPE SHOWN.
3. WOVEN OR NONWOVEN FILTER FABRIC, FDOT TYPE D-3.
4. SEE THE LATEST EDITION OF FDOT INDEX 199 FOR ACCEPTABLE SECURING DEVICES.
5. COST OF FILTER FABRIC JACKET TO BE INCLUDED IN THE COST OF PIPE CULVERTS.
6. INSTALLATION OF ALL PIPE AND STRUCTURES MUST MEET THE BEDDING, INSTALLATION AND BACKFILL REQUIREMENTS FOR NEW STRUCTURES AND PIPE ON DETAIL SW-5.

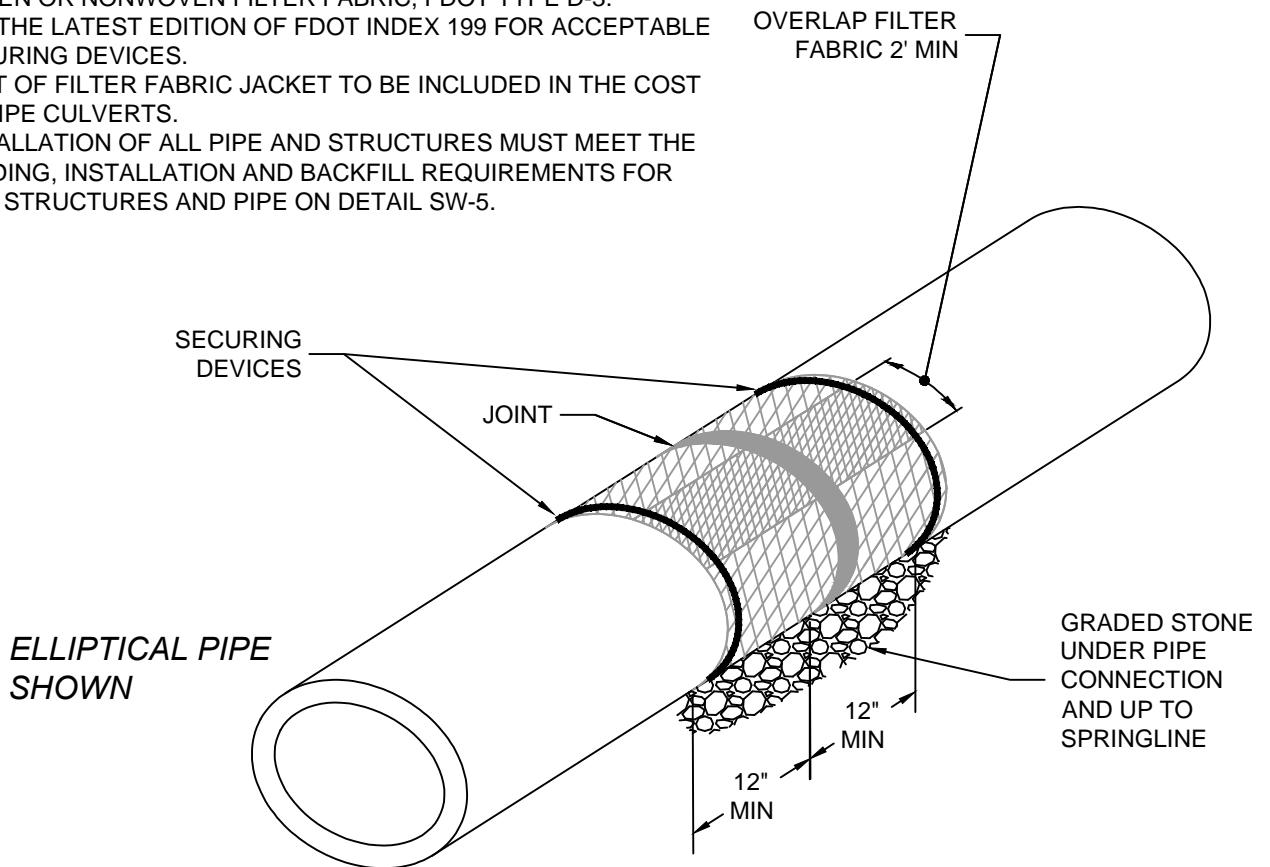

NOT TO SCALE

FILTER FABRIC JACKET FOR STORMWATER PIPE

JUPITER UTILITIES
CONSTRUCTION STANDARDS AND DETAILS

DATE APPROVED: 10/2013
 DRAWING No. SW-7